

MCW ATEX SUSPENDED CRANE SCALES



MCWATEX with optional ring and swivelling hook

Industrial crane scales for use in areas classified as hazardous (Zone 1 and 2) in accordance with Ex II 2G IIC T4 X protection.

LITTLE SPACE IS TAKEN UP allowing the best use of the lifting devices. Predisposed for an upper connection ring and lower hook.

Fitted with test certificate obtained with sample weights, up to 15000 kg of capacity.

MAIN FEATURES

- Indicator with 16-key waterproof functional keyboard and fitted with **CESI 04 ATEX 102 EC-Type-Examination certificate**.
- LCD display with 6 25-mm high contrast digits and icons for showing the active functions.
- Precision: $\pm 0.03\%$ F.S.
- Built extremely sturdy in oven-fire painted sheet steel.
- Digital set-up and calibration programmable directly from keyboard using a sample weight.
- Operating temperature: $-10 / +70$ °C.
- Programmable digital filter and auto power saving function.
- Hermetically sealed rechargeable battery, with 160-hour operating time; rechargeable in safe area.
- Equipped with 230Vac 50 Hz battery charger to be used in safe area.

FUNCTIONS

- **KEYBOARD:** Zeroing, Automatic Tare, Presetable Tare, ID1 and ID2 10-digit Codes, Print and data transmission commands, selectable function command, on/off switching
- **SELECTABLE FUNCTIONS:** Simple display and/or with sensitivity HR x 10, Net/Gross, Input/Output, Weighs accumulation (with up to 10 storage values). Tare database (up to 10), Formula weighing, Counting (Max. Resolution of 1.500.000 divisions) with function of entering the known A.P.W., lb/kg conversion, Hold, Set-point on gross weight, set-point on net weight.

OPTIONS ONLY AVAILABLE AT TIME OF ORDER

- Rechargeable battery pack

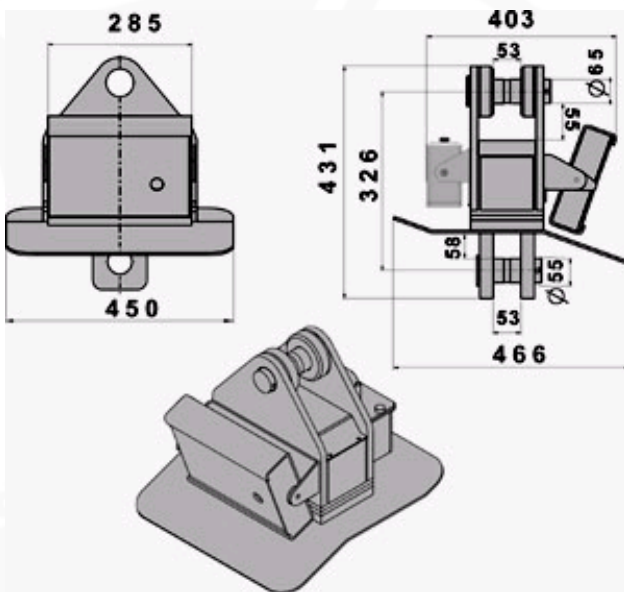

MCWATEX - dimensions in mm

Available versions

| Code | Max Capacity kg | Division kg |
|-----------|-----------------|-------------|
| MCWATEX6 | 6000 | 1 |
| MCWATEX10 | 10000 | 2 |
| MCWATEX15 | 15000 | 2 |
| MCWATEX25 | 25000 | 5 |
| MCWATEX35 | 35000 | 10 |

Options only available at time of order

| Code | Description |
|-------------|--|
| DFWBP76ATEX | Rechargeable ATEX battery pack, for weight indicator, pallet truck scale, or crane scale. |
| | NOTE: in the applications with the weight indicator mounted on a column or cart, the installation requires the STFA bracket. |

Accessories

| Code | Description |
|--------|---|
| GG15 | Swivelling bottom hook with safety lock 15 t |
| GG22 | Swivelling bottom hook with safety lock 22 t |
| GG30 | Swivelling bottom hook with safety lock 30 t |
| CA15 | Connection ring 15 t |
| CA30 | Connection ring 30 t |
| CA40 | Connection ring 40 t |
| UKPLUG | Power adapter from Schuko to BS1363. |
| TECMAN | Printed technical manual (free, if downloaded from the web) NET PRICE |
| UMAN | Printed user manual (free, if downloaded from the web) NET PRICE |

MEASUREMENTS OF HOOKS AND RINGS IN MM

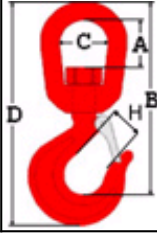
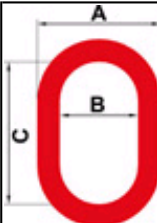
| | Code | A | B | C | D | H |
|---|-------------|-----|-----|-----|-----|----|
|  | GG15 | 95 | 354 | 96 | 455 | 63 |
| | GG22 | 121 | 432 | 120 | 565 | 80 |
| | GG30 | 133 | 568 | 139 | 667 | 88 |
|  | CA15 | 174 | 110 | 200 | | |
| | CA30 | 270 | 180 | 340 | | |
| | CA40 | 292 | 190 | 350 | | |

Dini Argeo S.r.l.

Copyright 2002-2008 - All Rights Reserved -

www.diniargeo.com

[Privacy Policy](#)

 **DINI AR GEO**
Scales - Weighing systems
www.diniargeo.com



NOTIFIED COMPANY ISO 9001: 2000

SALES AND TECHNICAL ASSISTANCE SERVICE



Weightronic Technology Ltd.

G/F., 34 Nam Cheong Street,
Sham Shui Po., Kln., Hong Kong.
Tel: (852) 2381 8818 Fax: (852) 2391 9919
Email: sales@weightronic.com
[http:// www.weightronic.com](http://www.weightronic.com)

MCW807V01-NEN

DINI AR GEO S.R.L.

Sede / Head Office

Via della Fisica, 20
41042 Spezzano di Fiorano
Modena - ITALY
Tel.+39 0536 843418
Fax+39 0536 843521
info@diniargeo.com

DIVISIONE PESE A PONTE

DINI AR GEO WEIGHBRIDGES

Via della Industria Nord
45030 Calto
Rovigo - ITALY
Tel. +39 0425 804097
Fax +39 0425 804842

SERVICE ASSISTANCE

ITALY

Via dell'Elettronica, 18
41042 Spezzano di Fiorano
Modena - ITALY
Tel. +39 0536 921784
Fax +39 0536 926654
service@diniargeo.com

SERVICE ASSISTANCE

Dini Argeo GmbH - Germany

Hauptstrasse, 2
74889 Sinsheim
Germany
Tel. +49-7261-405380
Fax +49-7261-4053899
info.de@diniargeo.com